

ABS submersible drainage pump J MEX (MSHA)

ABS submersible drainage pumps J 10 - 350 MEX are approved explosion proof mine pumps suitable for pumping water and dirty water mixed with light abrasive soil. Approved MSHA (Mine Safety and Health Administration) and D.O.E.R. (Pennsylvania Department of Environmental Resources). Applications include gassy coal mines, tunnels, strip mines, and quarries where MSHA permissibility is required.

1 Convenient handling – designed to make your life easier

Lightweight silumin parts makes transport, handling and installation easy.

2 Reliability

Compact design with durable silumin housing and mechanical shaft seals in silicon carbide provide a pump that you can rely on.

ABS Seal minder moisture detector protects the pump if seal leakage occur.

3 Reliable operation – minimizes time for maintenance

Double outer casing and good heat transfer enables pump to operate continuously at low levels or even run dry without damaging the motor.

Thermal overload protection shuts off the pump upon an overtemp. condition.

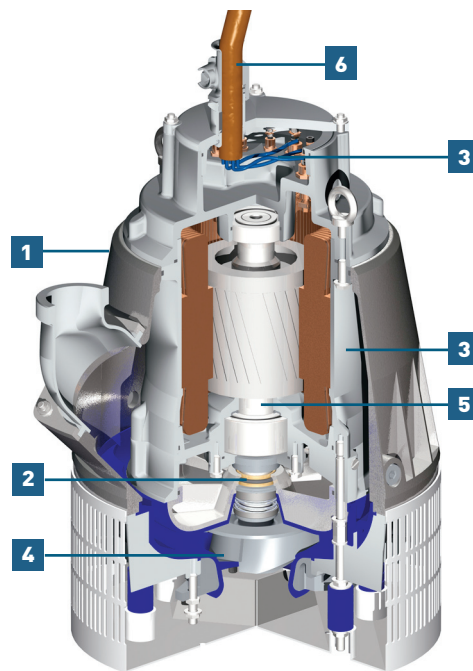

4 Wear resistance – one investment, years of cost efficient pumping

Stainless steel impeller, shaft and hardware as well as adjustable wear parts in oil resistant nitrile rubber provide a long life and high efficiency.

5 Robust design

Rigid stainless steel shaft with heavy duty bearings gives vibration free operation.

6 Complete supply - MSHA approved pump and panel

All J MEX series are equipped with MSHA approved power cable and are supplied with a manual or automatic control panel.

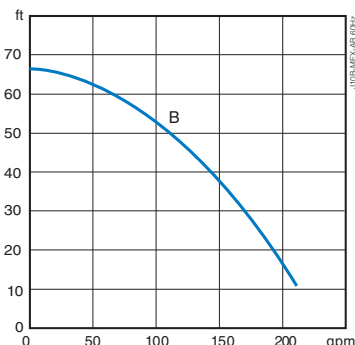

ABS J 10B MEX

J 10B MEX

Motor rating P ₂	1.8 Hp
Voltage (V):	Dual 230/460 or 575
Full load amps (A):	Dual 7.0/3.5 or 2.8
Speed:	3450 rpm
Free passage	3/16" x 3/4"
Discharge connections	Thread NPT 3"; NPSH 2"
Weight	125 lb
Motor protection	thermal overload sensors
Electric cable	50 ft

3-phase

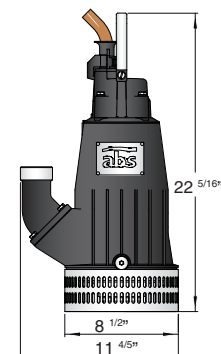

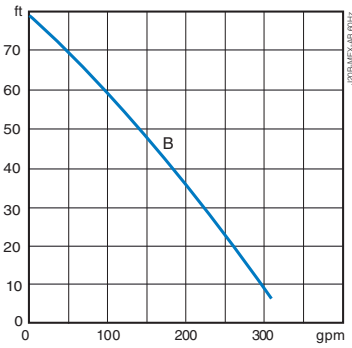

ABS J 20B MEX

J 20B MEX	3-phase
Motor rating P ₂	3.6 Hp, 3 ~
Voltage (V):	460 or 575
Full load amps (A):	5.4 or 4.3
Speed:	3450 rpm
Free passage	3/16" x 3/4"
Discharge connections	Thread NPT 3"; NPSH 2"
Weight	135 lb
Motor protection	thermal overload sensors
Electric cable	50 ft

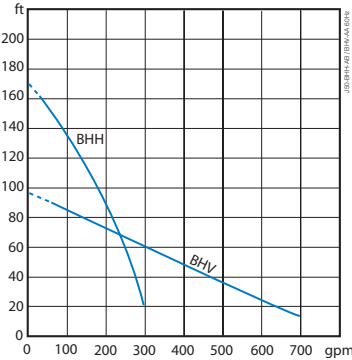
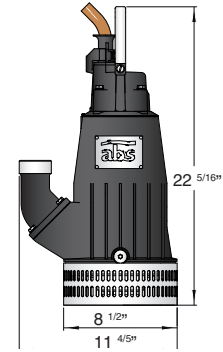

ABS J 50B MEX

J 50BHH MEX	3-phase
J 50BHV MEX	3-phase
Motor rating P ₂	8.2 Hp, 3 ~
Voltage (V):	460 or 575
Full load amps (A):	10.3 or 8.2
Speed:	3450 rpm
Free passage	1/4" x 1 5/16"
Discharge connections	Thread NPT 4"; NPSH 3"
Weight (excl. cable)	120 lb
Motor protection	thermal overload sensors
Electric cable	50 ft

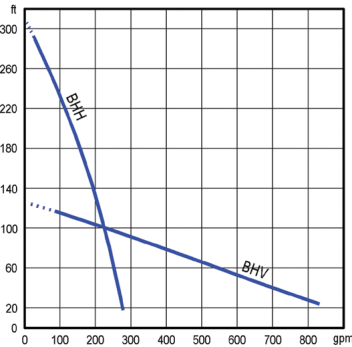
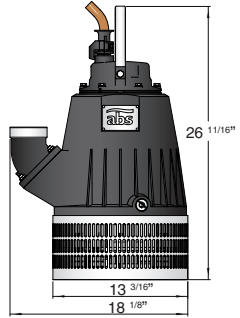

ABS J 80B MEX

J 80BHH MEX	3-phase
J 80BHV MEX	3-phase
Motor rating P ₂	13.6 Hp, 3 ~
Voltage (V):	460 or 575
Full load amps (A):	16.2 or 13.0
Speed:	3450 rpm
Free passage	1/4" x 1 5/16"
Discharge connections	Thread NPT 3", 6"; NPSH 4", 6"
Weight (excl. cable)	177 lb
Motor protection	thermal overload sensors
Electric cable	50 ft

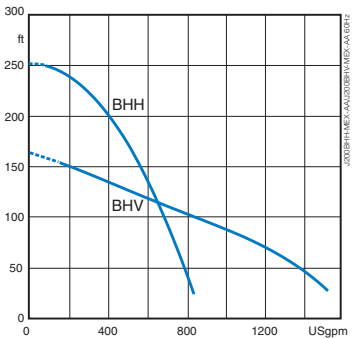
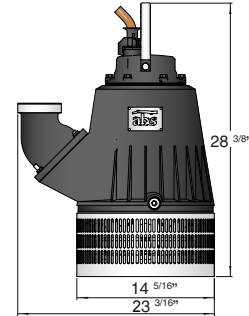

ABS J 200B MEX

J 200BHV MEX	3-phase
J 200BHH MEX	3-phase
Motor rating P ₂	31.3 Hp, 3 ~
Voltage (V):	460 or 575
Full load amps (A):	38.2 or 30.6
Speed:	3450 rpm
Free passage	1/4" x 2"
Discharge connections	Thread NPT 4", 6"; NPSH 4"
Weight (excl. cable)	377 lb
Motor protection	thermal overload sensors
Electric cable	50 ft

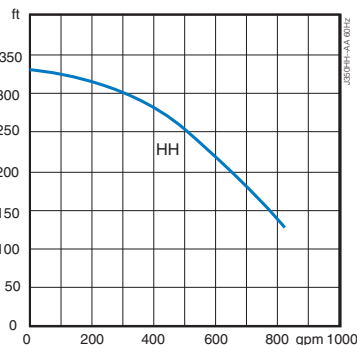
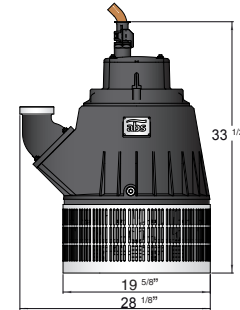

ABS J 350B MEX

J 350HH MEX	3-phase
Motor rating P ₂	59.8 Hp, 3 ~
Voltage (V):	460 or 575
Full load amps (A):	69 or 55.2
Speed:	3550 rpm
Free passage	1/4" x 2"
Discharge connections	Thread NPT 4", 6"; NPSH 4"
Weight (excl. cable)	493 lb
Motor protection	thermal overload sensors
Electric cable	50 ft

